

Electric Vibrators
Operating Instructions

Models
Three Phase
60 Hertz

- QT2-1500X-3
- QT2-2000X-3
- QT2-2500X-3
- QT2-3500X-3
- QT2-4500X-3



Jamieson Equipment Co.
5314 Palmero Court | Buford, GA 30518
678.745.3020 | 800.875.0280 (Toll Free)
www.jamiesonequipment.com
sales@jamiesonequipment.com





TABLE OF CONTENTS

	Page
Safety Precautions	3
I. Introduction	4
II. Operation	4
III. Specifications	4
IV. Installation Procedures	4
V. Channel Irons - How to Mount	5
VI. Mounting Locations	6 - 7
VII. Channel Iron Dimensions	7
Vibrator Bolts & Required Torque	7
VIII. Wiring Electric Vibrators	8
IX. Voltage & Amperage Readings	8 - 9
X. Wiring Diagrams	10
XI. Three Leading Causes of Electric Vibrator Failure	11
XII. Weight Setting Adjustments	12 - 14
XIII. Dimensions	15
XIV. Parts List & Parts Explosion	16
XV. Performance	17
XVI. Maintenance	17 - 20
XVII. Troubleshooting	21



SAFETY PRECAUTIONS

- Follow wiring and installation wiring instructions.
- A licensed electrician should adhere to all electrical codes when wiring three phase and direct wired single phase vibrators.
- Take amperage and voltage readings upon completion of installation. See page 9 for run and start amp draws for each vibrator and pages 8 - 9 for more information on voltage drops.
- High amperage reading means something is wrong and the vibrator may be damaged or not mounted properly. Do **not** operate a vibrator that pulls high amps.
- Operate a 3-phase unit with proper overload protection. Failure to comply voids warranty.
- For single-phase vibrators, use a properly grounded 3-prong receptacle. Do NOT use an extension cord without determining the appropriate wire gauge necessary to prevent excessive voltage drop over the length of the extension cord. See page 9 for instructions on how to calculate the proper size of extension cord needed to prevent vibrator failure.
- Make sure all electrical connections are secure and will not vibrate loose.
- Follow all mounting instructions.
- Bolt vibrator to a flat surface, across a long vertically oriented channel iron flush to the outside of the hopper wall.
- Contact factory if you are unable to closely follow all installation instructions or if amperage readings are high.
- Attach a safety cable or chain from vibrator to an independent stronghold.
- Prior to use, check vibrator for damage (cracked junction box, loose wires, missing end covers, etc.) Do not operate a damaged vibrator.
- Maximum ambient operating temperature is 104° F (40° C).
- Do not mount electrical control boxes onto structure (bin/hopper) wall to be vibrated.
- Do not operate vibrators when structure is empty.
- Do not operate vibrators when gate is closed or conveyor is stopped unless consolidation of material is desired.
- Wear ear protection for 90+ decibel levels.
- Do not operate vibrators without side covers.
- Always disconnect electricity before maintenance.
- Follow OSHA regulation Standard 1910.147 for lockout/tagout program.



I. INTRODUCTION

For optimum performance, cycle the vibrator on and off. The vibrator acts as a friction reducer and once the bulk solid is set into motion, gravity should do the rest. Do not operate the vibrator on an empty hopper or truck bed as this may cause structural damage to the hopper.

Vibrators should be operated only when discharge gates are open or truck bed is in an unloading position. Operating the vibrator with the discharge gate closed will cause the material inside the structure to compact.

Vibration has two important elements – Frequency and Amplitude. Frequency is the speed (rpm) or the number of vibrations per minute. The speed is controlled by a rheostat. Amplitude is the unbalance or amount of force produced by the eccentric weight. The faster the eccentric weights turn the more force output generated. Force and frequency work together. It is not necessary to use a lot of force when you have the appropriate frequency.

II. OPERATION

These electric vibrators are built for continuous duty, however the vibrators may be cycled on and off for intermittent duty. **The minimum time between consecutive starts is two (2) minutes.** Each time the vibrator starts it draws high amperage, therefore allow vibrator to cool or run for two minutes before starting again.

Do not operate the vibrator on an empty hopper. The vibration will vibrate the hopper and the vibrator causing damage if no bulk material is present. When the vibrator is mounted rigidly the vibration will pass through the structure and resonate the material inside the hopper.

Operate vibrators when discharge gates are open unless compaction of material is desired. The vibrator should appear motionless.

III. SPECIFICATIONS

- Vibrator housing is cast aluminum & weight covers are 304 stainless steel.
- Epoxy powder paint (120 µm thickness), polymerized in oven at 392°F / 200°C.
- Adjustable weights with graduated indicator from 0 to 100% of centrifugal force.
- Operating Temperatures: -4°F to 104°F (-20°C - 40°C).
- Insulation Class F (311°F / 155°C).
- Mechanical protection = IP 66 (Total protection against dust and high pressure water).
- Designed for continuous duty (type S1) with weights set at maximum centrifugal force.
- Labyrinth system grease seal: ensures correct and long life lubrication.

IV. INSTALLATION PROCEDURES

The key to successful vibration is the proper installation of the vibrator.

The axis of rotation of the eccentric weights, which are found on the ends of the motor shaft, should rotate toward the desired direction of material flow. In hopper applications, the weights should rotate towards the bin wall and down. The shaft of the vibrator should ideally be in a horizontal position to prolong bearing life.

Guidelines for the mounting industrial vibrators:

1. All QT2 Three Phase models - Mount vibrator with cord facing downward - Figure 1 on page 5.
2. Direction of rotation for three phase vibrators cannot be set at the factory.
3. Remove one of the weight covers from unit.
4. "Bump" the starter just long enough to determine the direction of rotation.
5. If rotation is incorrect, switch connections on any two legs of the circuit.
6. Replace weight cover making sure the o-ring is in the proper position.

Caution!

Do not mount the vibrator directly to the structure wall. Use a channel iron stiffener for proper mount rigidity and as the transducer of the vibrational energy.

V. CHANNEL IRONS HOW TO MOUNT

The key to successful vibration is a proper mount because rotary vibration resonates the material *inside* the structure. The vibrator should appear motionless. There should not be a large amount of motion or noise. Follow the instructions on how to mount the vibrator and you will get great results.

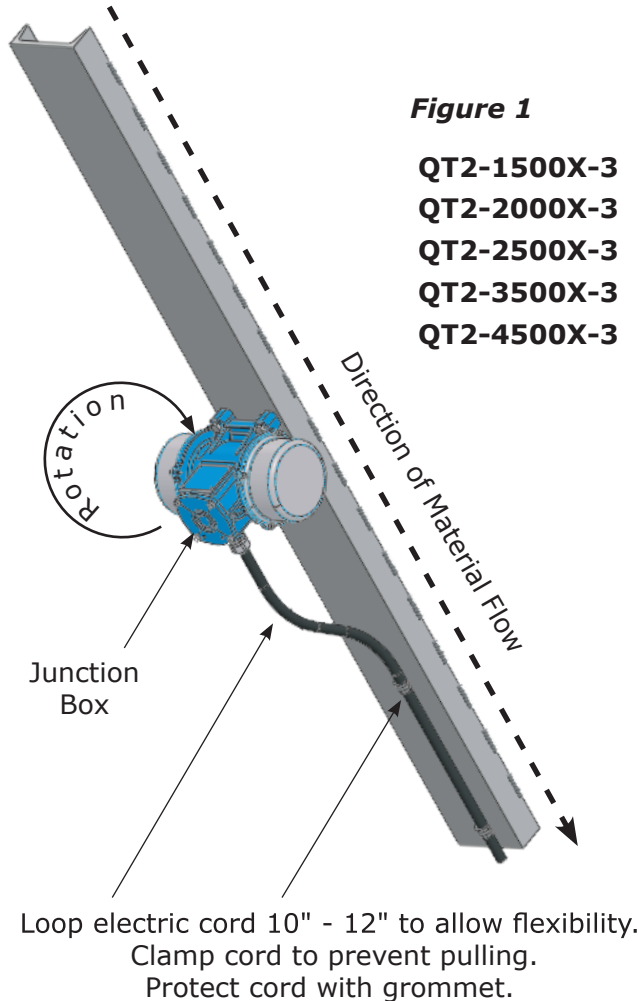

The channel iron should be at least two-thirds the height of the sloped portion of the hopper, but not less than 6' (1.8 m) or greater than 10' (3 m) in length. The channel iron width should not be less than the base width of the vibrator. If the vibrator does not sit flat, the plate may be warped. Shim the vibrator prior to mounting to compensate for any warping. **See Table on page 7 for recommended channel iron.** DO NOT install more than one vibrator on the same channel iron or use a channel iron shorter than the recommended length. A short channel may flex the bin wall.

Important!

The channel iron should be at least two-thirds of the height of the sloped portion of the hopper but no greater than 10 feet (3 m).

Attach the vibrator to the channel iron. Drill holes in the channel iron to accept mounting bolts. Weld proper size nuts to the back side of the channel iron before installing channel iron to the bin wall.

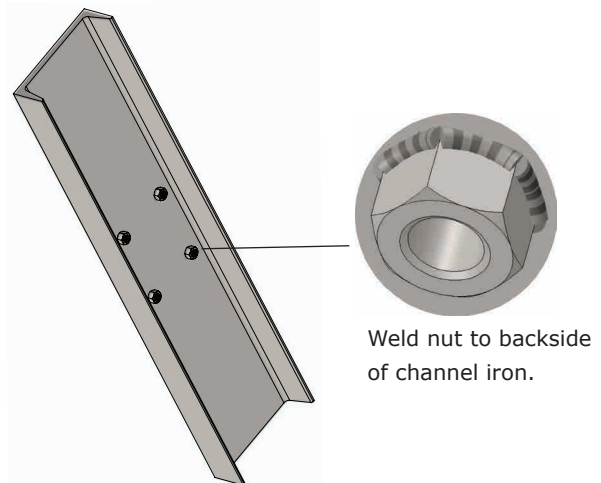

Stitch weld the channel iron vertically to the slope portion of the bin wall. Weld 3 inches (7.5 cm), skip 1 inch (2.5 cm), weld 3 inches (7.5 cm), etc... Leave 1 inch (2.5 cm) un-welded on the ends and corners. This allows the vibration to dissipate out the ends of channel without causing stress cracks to the hopper or bin. By doing so, should the weld fail, the entire mount will not fall off. Do not mount the channel iron horizontally.

Secure the vibrator to the channel iron with SAE coarse thread grade 5 plated bolts with lock washers or an adhesive such as Loctite® 262. Tighten bolts in a sequential process. At least two passes are required in most situations. Give all bolts the same torque value. Grade 5 bolts can handle more torque than standard bolts. If Loctite® is not used, torque the bolts after the vibrator has operated for a few minutes and check tightness often. If Loctite® is used do not torque the bolts a second time as this will break the Loctite® bond.

Attach a safety cable to a stronghold (not the channel iron mount), which is higher than the mounted vibrator and capable of holding the vibrator's weight.

VI. MOUNTING LOCATIONS

Single Vibrator

Install a channel iron stiffener on the outside of the sloping wall 1/3 the distance above the discharge opening.

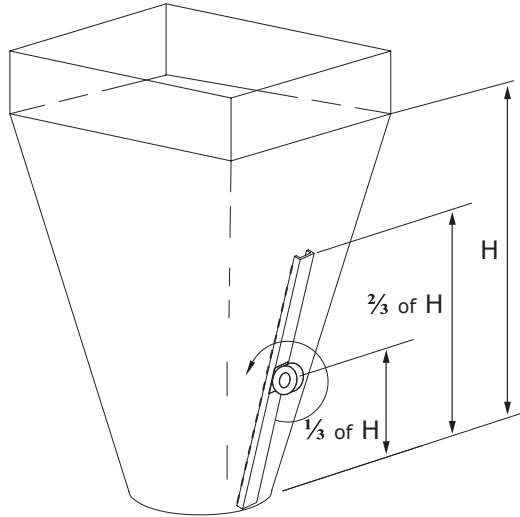

Multiple Vibrators

Use more than one vibrator when the diameter or width of any wall is greater than 12 feet (3.66 m). Always mount the vibrators on different planes.

Two Vibrators on Round or Square Hoppers

Install channel iron stiffeners 180° apart. Install one vibrator on the outside of the sloping wall 1/3 the distance above the discharge opening. Install the second vibrator on the outside of the opposite sloping wall 2/3 the distance above the discharge opening.

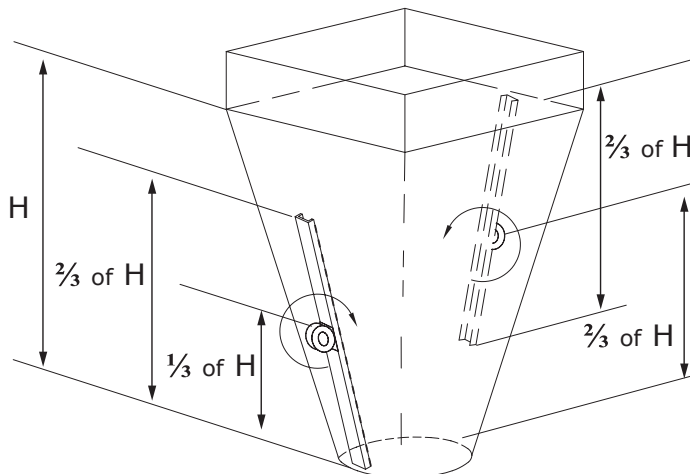

Three Vibrators

Install channel iron stiffeners mounted 120° apart. Install the first vibrator on the outside of the sloping wall 1/4 the distance above the discharge opening. Install the second vibrator on a separate channel iron at 1/2 the distance above the discharge opening. Install the third vibrator on the remaining channel iron at 3/4 the distance above the discharge opening.

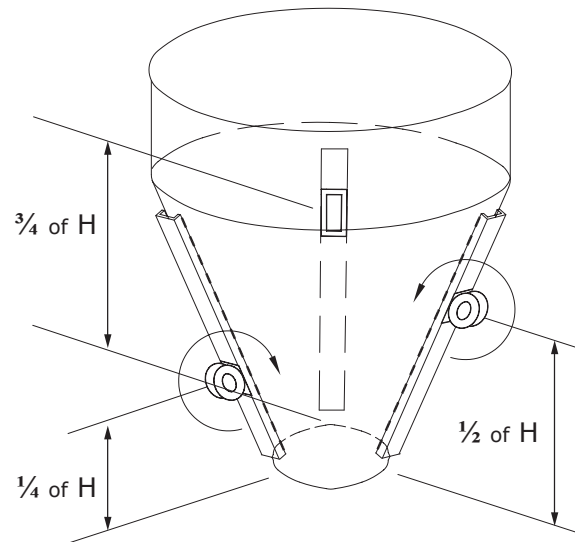

Two Vibrators on Rectangular Hoppers

Install channel iron stiffeners on opposite sides of the long walls. Install one vibrator on the outside of the sloping wall 1/3 the distance from the discharge opening. Install the second vibrator on the outside of the opposite sloping wall 2/3 the distance above the discharge opening. When only one wall slopes, mount both stiffeners on it. Equally space the stiffeners on the wall. Place one vibrator 1/3 above the discharge opening on one channel iron and the other vibrator 2/3 above the bin's discharge opening on the second channel.

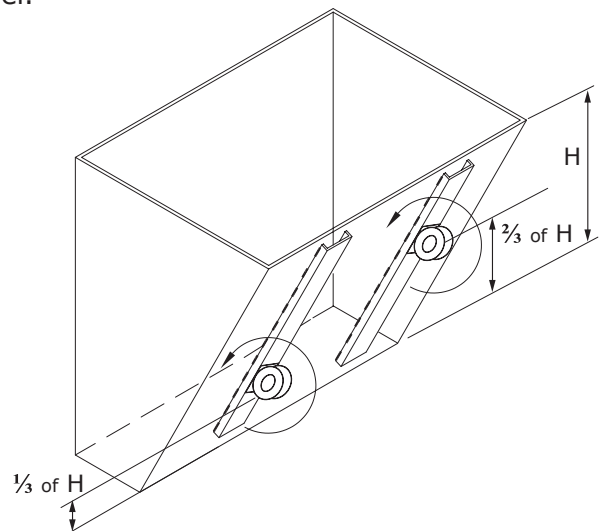

Installation on Chutes and Flow Pipes

Mount channel iron stiffeners vertically or in the direction of material flow. Center the channel if the chute is less than 6 feet (1.83 m) in width. If the chute is greater than 6 feet in width, use two vibrators on separate channel irons. To maximize each vibrator's radius of influence; center each channel iron in each half of the chute. Each channel iron should be located $\frac{1}{4}$ of the chute width from the edge and $\frac{1}{2}$ of the chute width apart. (e.g. – for a chute 8' wide, the channel iron locations would be 2' from each edge and 4' apart.) When chute thickness is less than $\frac{1}{8}$ " , additional reinforcement may be required.

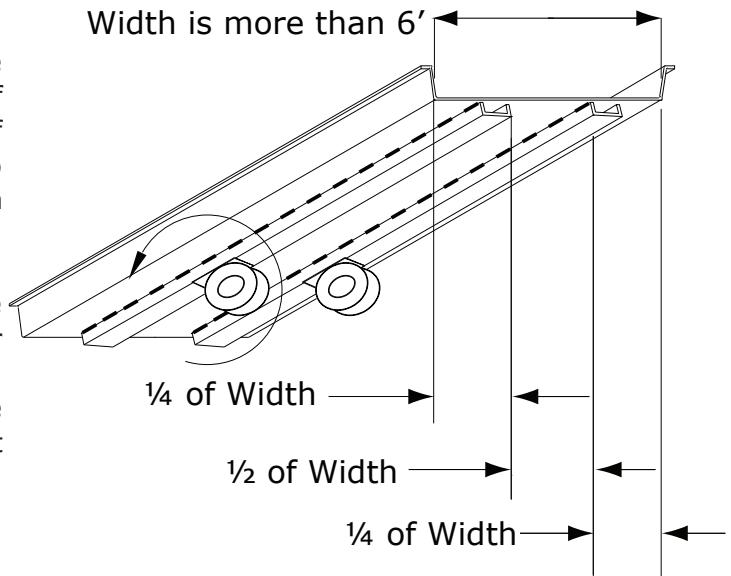

VII. CHANNEL IRONS and BOLT SIZES with TORQUE VALUES

Channel Iron Dimensions for Electric Vibrators				
Vibrator Model 3 Phase	Width	Minimum Web Thickness	Minimum Length	Weight Per Length
	inch	inch	feet	lb/ft
	mm	mm	mm	kg/m
QT2-1500X-3 QT2-2000X-3 QT2-2500X-3	8.0	.487	6	18.75
QT2-3500X-3 QT2-4500X-3	203	12.4	1829	28

Make channel iron length at least 2/3 the height of the slope section of the bin without exceeding 10' (3 M) in length.

Vibrator Bolts and Required Torque		
	Drill Holes in Channel Iron Weld Nuts to Back Side of Channel Iron	Torque
QT2-1500X-3 QT2-2000X-3 QT2-2500X-3 QT2-3500X-3, QT2-4500X-3	.65 (17 mm) diameter hole $\frac{5}{8}$ " - 11 UNC Grade 5 Plated Weld $\frac{5}{8}$ " - 11 UNC Nut on Underside of Channel	169 lb-ft (229 N-m)



VIII. WIRING ELECTRIC VIBRATORS

Only a qualified electrician should connect an electric vibrator to a power source. Using power of incorrect voltage or phase or inadequate wire size will damage the vibrator and void the manufacturer's warranty.

Always measure the amperage on all legs of the supplied power after installing the vibrator. If the amp draw exceeds that specified on the motor nameplate, turn off the vibrator immediately. Operating an electric vibrator with an excessive amp draw will lead to premature motor failure that is not covered by the manufacturer's warranty.

The cause for a high amp draw must be determined and corrected before operating the vibrator. **Possible causes of high amp draw:**

1. A non-rigid mount
2. Low voltage (from power source or due to inadequate wiring or extension cord)
3. Incorrect voltage
4. Vibrator has too much force

It is recommended that the initial amperage readings be recorded for future reference. **If you cannot determine the cause of a high amp draw, do NOT operate the vibrator.** Call Global Manufacturing customer support at 1-800-551-3569. When seeking customer technical support, please provide the product serial number, voltage and phase of the power source, and the initial amperage readings. If you periodically check the amperage, an increase in the amp draw will indicate the onset of a problem such as decreased or fluctuating voltage, loose mount bolts, or a loss in rigidity of the mount. **High amp readings should never be ignored.**

All three phase vibrators must have overload protection to validate the warranty. These vibrators do **not** come with overload protection. Use the correct heater size recommended by the manufacturer of the overload protector. **Never use a higher rated heater.** If the wrong overload protection is used the warranty will be void. Consult a qualified electrician.

Global 3-phase vibrators have a dual voltage motor which can be wired for either 230V or 460V. Electric vibrators are normally wired at the factory for the voltage desired by the customer. If the voltage

needs to be switched have a qualified electrician change the connections in the junction box on the vibrator following the wiring instructions included in this manual. Keep in mind that a single phase motor cannot be changed to a three phase motor and visa versa. If you need to change the phase of the motor, please contact the distributor from whom you purchased the electric vibrator.

Single phase vibrators are single voltage motors and cannot be wired for a different voltage. They are only available in 115 Volt.

IX. VOLTAGE & AMPERAGE READINGS MUST BE DONE PRIOR TO OPERATING VIBRATOR

Important!

Typically, motors can tolerate a 10% drop in voltage while running. Since start-up lasts only 1 to 2 seconds, a 20% drop should be tolerated for that short period of time when the motor is pulling higher amps. The best way to check this is to use a voltage meter at the motor. **Check minimum voltage during start-up and the running voltage** once the motor has reached its running speed. Assuming 120 volt motor, it needs at least 96 volts during start-up, and once the motor reaches its operational speed it needs 108 volts. When **sizing an extension cord** one must be careful because the extension cord is only one source of voltage drop. The power source might also fluctuate. It is best to assume the power source could fluctuate by 5%. Thus the 120 volt source might at times only provide 114 volts. Therefore, the extension cord cannot cause more than a 15% voltage drop during start-up and only a 5% drop after reaching operational speed. With a 100' 14AWG copper wire extension cord, one would get a 20.231 voltage (16.86%) drop during motor start-up when pulling 39 amps. This means the voltage at the vibrator might be as low as 93.77 volts, too low for proper starting. Once the vibrator reaches full speed it pulls only 2.6 amps. The voltage drop here would be 1.349 volts leaving 112.65 volts, which should be sufficient to keep the unit running. HOWEVER, the low voltage during start-up causes excess heat that degrades the motor insulation. This effect is cumulative, so even though the vibrator starts the



first, second, or third time the damage done by low voltage is building. Eventually the insulation fails and the motor will burn up. In this example only the start windings will fail prematurely, which will leave the vibrator inoperable.

To further explain voltage drops pertaining to the above example:

If a 12AWG cord is used the voltage drops will be:
 Start-up=12.733 volts giving a net of 101.3 volts
 Run=0.849 volts giving a net of 113.2 volts
This extension cord would be adequate.

If a 10AWG cord is used the voltage drops will be:
 Start-up=8 volts giving a net of 106 volts
 Run=0.534 volts giving a net of 113.5 volts
This extension cord would be better.

There is a good website with a nice voltage drop calculator. If you have the wire size, length, power source voltage, and amp draw it will calculate the voltage drop.

http://www.powerstream.com/Wire_Size.htm

YOU MUST ALSO CHECK THE AMP DRAW. If the amp draw exceeds the manufacturer's specifications then the vibrator is probably not properly mounted. The mount may not be level or lack proper rigidity. Please follow the mounting instructions in this manual.

Maximum Allowable Current Draw:

230 Volt - Three Phase		
Model #	Part #	Amps-Max Run (Start)
QT2-1500X-3	6332150	1.90 (11.4)
QT2-2000X-3	6332200	3.20 (12.8)
QT2-2500X-3	6332250	5.60 (28)
QT2-3500X-3	6332350	5.60 (28)
QT2-4500X-3	6332450	5.80 (34.8)
460 Volt - Three Phase		
QT2-1500X-3	6334150	.95 (5.7)
QT2-2000X-3	6334200	1.60 (6.4)
QT2-2500X-3	6334250	2.80 (14)
QT2-3500X-3	6334060	2.80 (14)
QT2-4500X-3	6334450	2.90 (17.4)

X. WIRING DIAGRAMS

Three Phase Diagrams for 230V & 460V:

QT2-1500X-3

QT2-2000X-3

QT2-2500X-3

QT2-3500X-3

QT2-4500X-3

3 Phase 230V D Connection

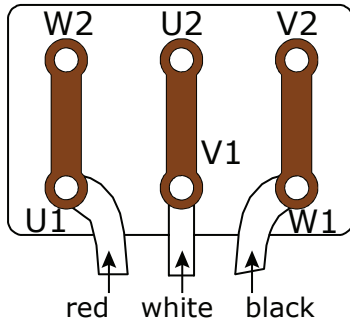

3 Phase 460V Y connection

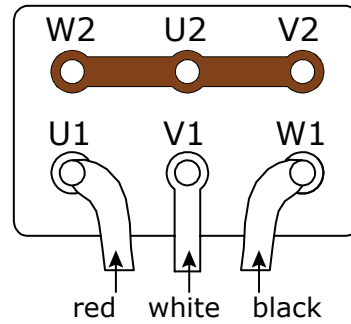

XI. THREE LEADING CAUSES OF ELECTRIC VIBRATOR FAILURE

1) Single Phasing:

A leading cause of failure in three phase motors is losing one of the three phases, called single phasing. Single phasing can be caused by blowing only one of the three fuses that protect the circuit, by a faulty contact in the motor starter, by losing a phase from the local electric utility, and numerous other ways. A vibrator that burns up due to single phasing is not covered under warranty. While heaters do an excellent job of protecting a motor from overload conditions, they often do not protect a three phase motor from single phasing.

2) Low Voltage:

Another failure point is low voltage caused by high starting current. An electric vibrator will take 2 to 3 seconds to reach full running speed. During this starting period, the vibrator draws more current than it draws at full running speed. The high starting current may cause the voltage to sag or drop below 80% of the rated voltage when measured at the vibrator. If **inadequate** voltage is provided initially, a voltage drop will cause problems. Low voltage may prevent the vibrator from reaching its rated speed, and cause the motor to continue to draw high starting current for a prolonged period until it burns up. The electric power circuit must be able to handle the high starting current without dropping below 80% of the rated voltage. The most common problems are using a long extension cord with the wire gauge undersized or an undersized transformer which cannot handle the high amp draw on start up.

3) Improper Mounting:

When an electric motor runs slower than its rated speed, it will draw excessive current and eventually burn up. A non-rigid mount hinders the vibrator from reaching full running speed. In screen and feeder applications, the vibrator may get "trapped" in the resonant frequency of the structure and not have enough power to reach full running speed. Adjust the springs if possible to change resonant frequency. **Improper mounting of the electric vibrator will cause it to fail.**

4) If a vibrator has too much force for the rigidity and weight of the application, it runs slower than its rated speed. Just as with the improper mount discussed above, the electric motor will draw excessive current and eventually burn up. All QT2 vibrators have adjustable weights. If the vibrator has too much force for the application and is pulling high amps, adjust the weights to a lower force setting (see Weight Setting Adjustments below) and recheck the amp draw. If the weights are set to the minimum force setting, and the vibrator still draws excessive current, either a smaller vibrator is needed or something must be done to re-enforce the bin or hopper to make it more rigid. Do NOT run an electric vibrator that is drawing excessive current. It will overheat causing damage to the insulation and result in pre-mature failure.

XII. WEIGHT SETTING ADJUSTMENTS



WARNING Always disconnect electricity before adjusting the weights. Follow OSHA regulation Standard 1910.147 for the control of hazardous energy (lockout/tagout).

The centrifugal force of the vibrator may be controlled by adjusting the eccentric weights. The speed of the vibrator is not affected by the adjustment of the eccentric weights.

All QT2 vibrators have double ended shafts with eccentric weights mounted at both ends. It is very important to adjust eccentric weights on both ends of the double ended shaft identically.

The weights on QT2 electric vibrators can be adjusted to produce 10 different force outputs. To adjust the weights:

1. Remove the four screws holding each stainless steel cover in place. Be careful so the o-ring seal on each cover is not damaged. There are either three, four, five, or six weights on each end of the shaft (depending on the model). There are two or three inner weights on each side, which are fixed to the shaft by a key. They cannot be rotated.
2. The adjustment of the weights is accomplished by loosening the nuts on both ends of the shaft and rotating the outer weights (*1 outer weight on QT2-1500X, 2 outer weights moved together as one on QT2-2000X, QT2-2500X, QT2-3500X, or three outer weights move together as one on QT2-4500X*). The elevations on each weight fit into the depressions on the adjacent weights preventing the weights from rotating in relationship to each other when the nuts on both ends of the shaft are tightened. There are 10 elevations on each weight, so ten different weight settings can be configured. The configuration of the weights must be EXACTLY the same on both ends of the vibrator shaft to prevent damage to the vibrator. See the possible weight configurations and their resulting force outputs in the table on the right.
3. Once the weights are set at the desired configuration tighten the nuts on both ends of the shaft so the weights are held in place and can only rotate with the shaft.
4. Re-install the covers using the four mount screws. Be sure the o-ring is properly placed to insure the covers are water tight.

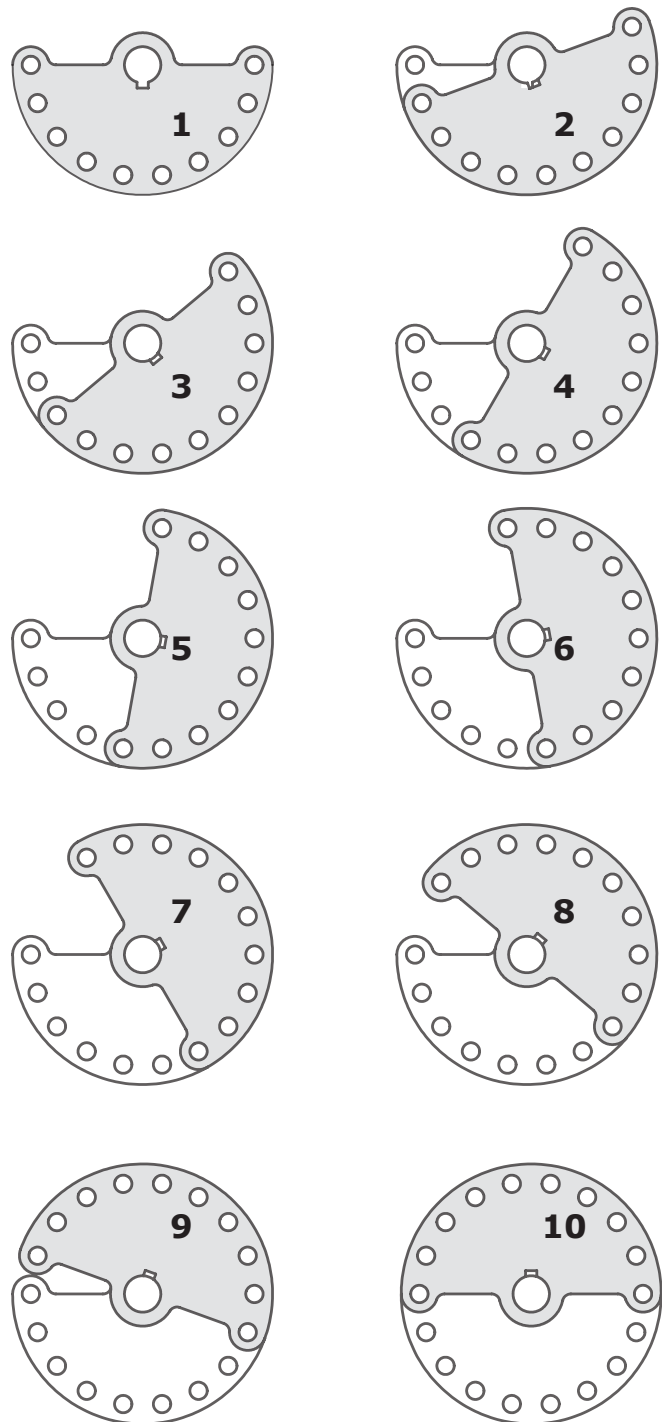
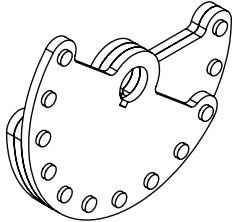
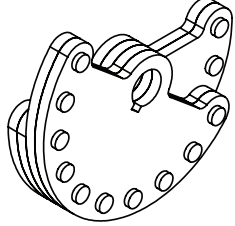

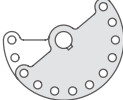
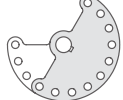
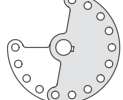
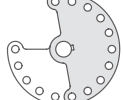
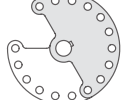
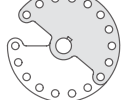
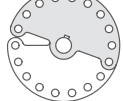
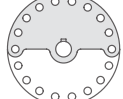

Illustration at the right is a representation of the adjustable weights. This is what one would see looking at the weights on the end of the shaft.

Adjustable Weight Configurations						
Models	QT2-1500X		QT2-2000X		QT2-2500X	
Number of weights on each shaft end						
	<i>2 Inner fixed weights 1 Outer adjustable weights</i>		<i>2 Inner fixed weights 2 Outer adjustable weights</i>			
Weight Configuration	Unbalance lb-in	Force lb-f	Unbalance lb-in	Force lb-f	Unbalance lb-in	Force lb-f
1 MAX 	4.60	1,555	6.60	2,231	9.03	3,052
	<i>Factory Settings</i>					
2 	4.55	1,539	6.53	2,209	8.94	3,022
3 	4.37	1,477	6.20	2,097	8.49	2,869
			<i>Factory Settings</i>			
4 	4.05	1,368	5.74	1,941	7.86	2,656
					<i>Factory Settings</i>	
5 	3.68	1,244	5.08	1,718	6.95	2,350
6 	3.174	1,037	4.22	1,428	5.78	1,954
7 	2.67	902	3.30	1,116	4.52	1,526
8 	2.16	731	2.31	781	3.16	1,068
9 	1.70	575	1.19	402	1.63	549
10 MIN 	1.52	513	0	0	0	0



See Weight Setting Adjustments on page 12 for instructions.

Adjustable Weight Configurations				
Models	QT2-3500X		QT2-4500X	
Number of weights on each shaft end				
	3 Inner fixed weights 2 Outer adjustable weights		3 Inner fixed weights 3 Outer adjustable weights	
Weight Configuration	Unbalance lb-in	Force lb-f	Unbalance lb-in	Force lb-f
1 MAX	11.28	3,814	13.45	4,548
			Factory Settings	
2	11.17	3,776	13.32	4,502
3	10.61	3,585	12.65	4,275
	Factory Settings			
4	9.82	3,318	11.70	3,956
5	8.80	2,975	10.63	3,502
6	7.45	2,517	8.61	2,911
7	5.98	2,022	6.73	2,274
8	4.40	1,488	4.71	1,592
9	2.93	992	2.42	8,19
10 MIN	2.26	763	0	0

XIII. DIMENSIONS

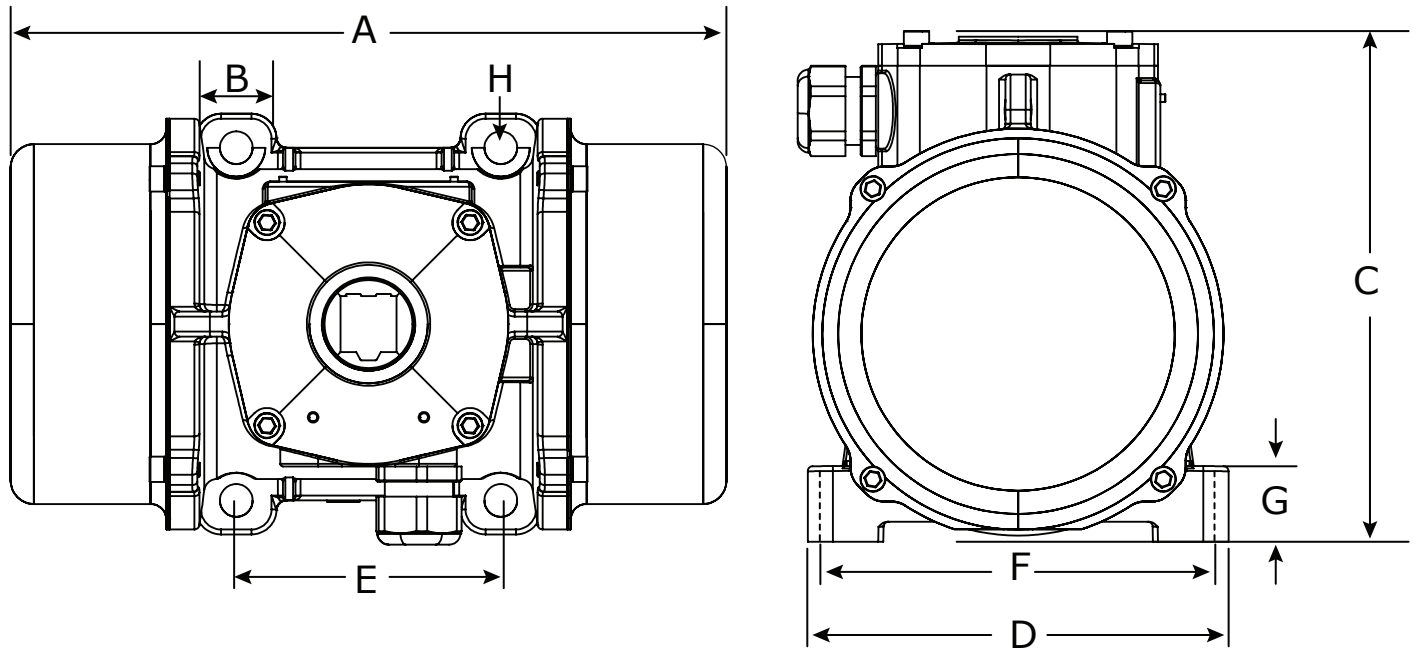

Dimensions For QT2-X Rotary Electric Vibrators

Vibrator Model	Weight	A	B	C	D	E	F	G	H
		Total Length	Foot Width	Total Height	Total Width	Bolt Hole Center Length	Bolt Hole Center Width	Foot Thickness	Bolt Hole Size
	lb	in	in	in	in	in	in	in	in
	kg	mm	mm	mm	mm	mm	mm	mm	mm
QT2-1500X	44	12.14	1.5	8.45	8.06	4.74	6.7	1.58	.65
	20	308	38	214.5	205	120	170	40	17
QT2-2000X	55.2	17.15	2.36	9.4	8.25	4.74	6.7	.88	.65
	25	436	60	239	210	120	170	22	17
QT2-2500X	72.4	17.25	2.84	10.1	9.06	5.5	7.47	1	.65
	32.8	438	72	257	230	140	190	25	17
QT2-3500X	78.3	17.25	2.84	10.1	9.06	5.5	7.47	1	.65
	35.5	438	72	257	230	140	190	25	17
QT2-4500X	113.5	18.05	3.21	9.27	9.06	5.5	7.47	.88	.65
	51.5	458	81.5	235	230	140	190	22	17

XIV. ELECTRIC VIBRATOR PARTS LIST & PARTS EXPLOSION FOR:

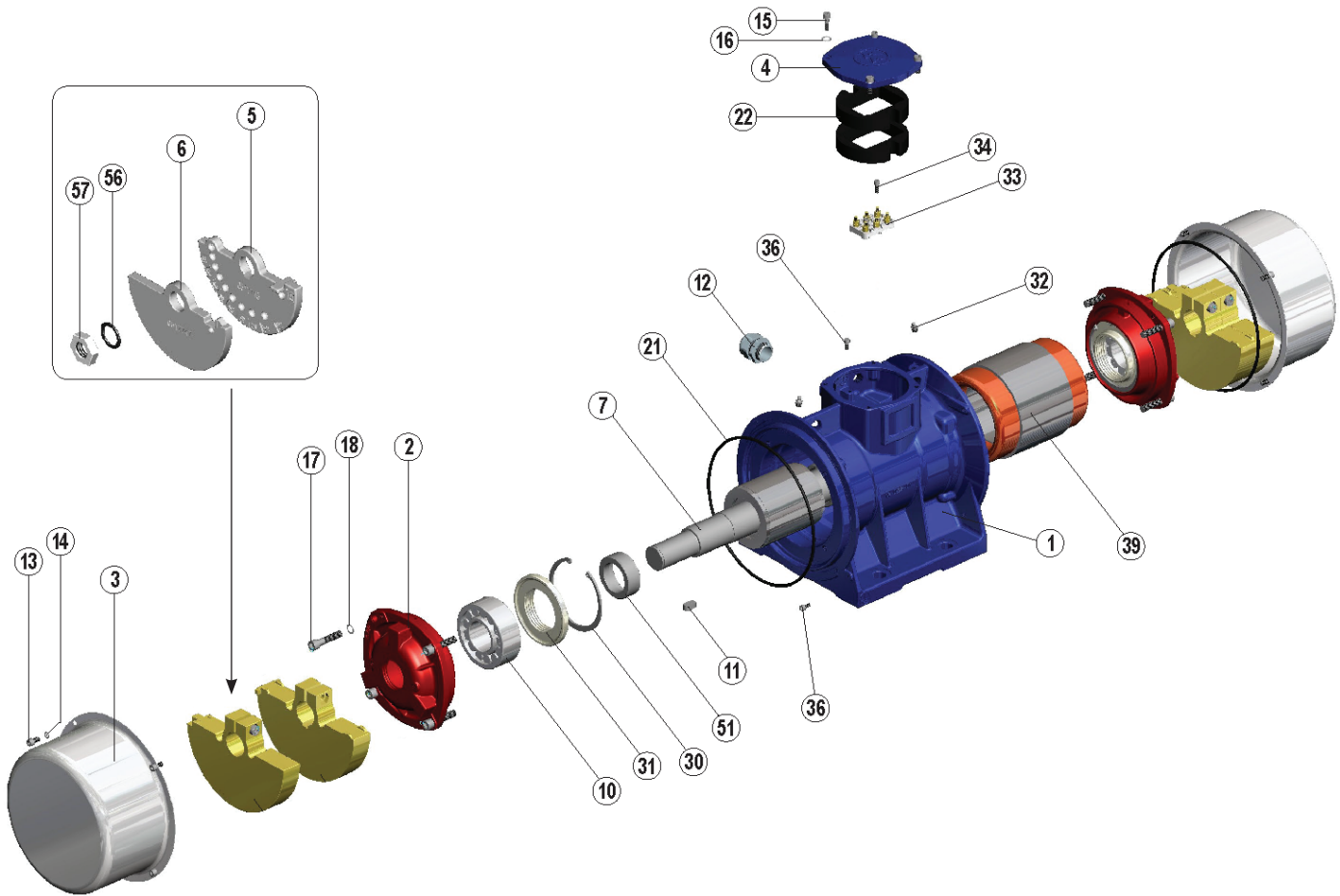

Parts List for Electric Vibrators - 60 Hz - QT2-2500-3

#	Description	Qty	#	Description	Qty
1	Vibrator Housing	1	17	Screw	8
2	Bearing Housing Flange	2	18	Washer	8
3	Weight Cover	2	21	Cover O-Ring Seal	2
4	Terminal Box Cover	1	22	Terminal Box Insulation	2
5	Fixed Weights	4-6	30	Retaining Ring	2
6	Adjustable Weights	2-6	31	Grease Retainer Cover	2
7	Shaft	1	32	Grease Fitting	2
10	Bearing - see page 18	2	33	Terminal Block	1
11	Key	2	34	Terminal Screws	6
12	Cord Restraint	1	36	Ground Screw	1
13	Cover Screw	8	39	Stator Winding	1
14	Cover Washer	8	56	Washer	2
15	Terminal Box Cover Screw	4	57	Nut	2
16	Terminal Box Cover Washer	4			



XV. PERFORMANCE DATA

Performance Data											
Three Phase - 230/460V - 2 POLE - 60 Hz Electric Vibrators											
VIBRATOR MODEL	Unbalance			Speed rpm	Force			Voltage volts	Amp Draw		Input Power watts
	Min	Factory Setting	Max		Min	Factory Setting	Max		Start	Run	
	lb-in kg-mm	lb-in kg-mm	lb-in kg-mm		lb kN	lb kN	lb kN		amps	amps	
QT2-1500X-3	1.52	4.6	4.6	3450	513	1555	1555	460	5.7	.95	650
	17.5	53	53		2.28	6.92	6.92	230	11.4	1.9	
QT2-2000X-3	1.19	6.2	6.6	3450	402	2097	2231	460	6.4	1.6	1,100
	13.7	71	76		1.79	9.33	9.92	230	12.8	3.2	
QT2-2500X-3	1.63	7.86	9.03	3450	549	2656	3052	460	15.4	2.8	1,900
	18.7	91	104		2.44	11.81	13.58	230	30.8	5.6	
QT2-3500X-3	2.26	10.61	11.28	3450	763	3585	3814	460	15.4	2.8	1,900
	26	122	130		3.39	15.95	16.97	230	30.8	5.6	
QT2-4500X-3	2.42	13.45	13.45	3450	819	4548	4548	460	17.4	2.9	2,100
	27.9	155	155		3.64	20.23	20.23	230	34.8	5.8	

XVI. MAINTENANCE

Always disconnect electricity before performing maintenance on any electric vibrator. Follow OSHA regulation Standard 1910.147 for the control of hazardous energy (lockout/tagout).

Quiet Thunder® electric vibrators are essentially maintenance-free. Periodically check the mount bolts to make sure they are tightened to the appropriate torque. It is especially important to check the tightness of the mount bolts when first installed and after three hours of service. The amp draw while the vibrator is running should be checked periodically. If it exceeds the amp rating on the vibrator tag, the vibrator should be checked for problems. A loose mount or failing bearings could result in a high amp draw. A vibrator should never be run when the amp draw exceeds the rating on the vibrator tag. If the bearings make any excessive noise while the vibrator is running they should be checked for wear or inadequate grease.

Vibrator bearings have been appropriately greased at the factory for long life. No further lubrication is needed for the life of the bearings for the QT2-1500X, which has ball bearings. These bearings must be replaced with ball bearings of identical characteristics once they have reached their useful life.

The QT2-2000X, QT2-2500X, QT2-3500X, and QT2-4500X have roller bearings. These bearings need to be serviced after every 5,000 hours. This requires that the grease be removed and replaced with new Klueber Isoflex NBU 15 grease. These models also have grease fittings, so that additional grease can be added periodically. This is especially important and will extend bearing life significantly when there are special conditions such as high ambient temperatures, running the vibrator continuously, or running at the highest force setting. The grease fittings allow additional grease to be added to the bearings without dismantling or disassembling the vibrator.

The bearings used in Quiet Thunder® electric vibrators have specific characteristics designed for heavy duty use in vibrators. Bearing service or replacement should be performed by competent personnel using the appropriate tools.



Bearing Specifications		
Model	Bearing Part Numbers	Load Capacity (lb)
QT2-1500X	6309-2Z-C4	12,434
QT2-2000X	NJ306E-TVP2-C4-BL	13,150
QT2-2500X	NJ2208E-TVP2-C4-BL	18,320
QT2-3500X	NJ2208E-TVP2-C4-BL	18,320
QT2-4500X	NJ2308E-TVP2-C4-BL	28,999

QT2-1500X Ball Bearing Replacement Procedures – This Quiet Thunder® Vibrator model has ball bearings that are permanently lubricated at the factory. Follow these procedures if the bearings have failed and new bearings need to be installed.

To remove the old bearings:

1. Disconnect the electrical power and lockout the power supply following OSHA 1910.147.
2. Disconnect the vibrator from the power source by opening the connection box on the vibrator and disconnecting the power cable from the terminal strip.
3. Remove the four fasteners holding the covers in place at each end of the vibrator. Remove the covers.
4. Note the position of the adjustable weights so they can be re-installed in the same position after replacing the bearings.
5. Remove the shaft nut and washer from each end of the shaft.
6. Remove the weights being sure not to lose the key that prevents the weights from rotating on the shaft.
7. Remove the retaining ring from each flange located at each end of the shaft.
8. Press the shaft from the vibrator housing. One bearing will be removed with it.
9. Remove the bearing from the shaft, then press the shaft through the housing in the opposite direction to remove the other bearing.

To install the new bearings:

1. Press one bearing into the flange at one end of the housing. Be sure it is fully seated in the flange.
2. Install the retaining ring into the flange to secure the bearing.
3. Install the shaft into the housing from the side opposite the installed bearing. The shaft should pass through the installed bearing.
4. Place the second bearing over the opposite end of the shaft and insert it into the flange in the housing. Using a press, be sure the bearing is fully seated in the flange.
5. Install the retaining ring into the flange to secure the second bearing.
6. Rotate the shaft. It should turn easily by hand with no binding.
7. Mount the two inner weights on each end of the shaft. Be sure the key engages fully, so the two inner weights turn with the shaft.
8. Install the outer adjustable weight as it was positioned in #4 above. The weight setting must be identical on both ends of the shaft.
9. Secure the weights by installing a washer and nut on each end of the shaft.
10. Install the covers using the four mount fasteners. Be sure the o-rings are properly seated.
11. Connect the power cable to the power strip in the connection box. Be sure to follow the wiring diagram for the appropriate phase and voltage being used.
12. Reconnect the electrical power. Be sure to take amp readings before returning the vibrator to service. If the amp readings are high, but the shaft turns freely, there could be excess grease in the new bearings. Remove the covers and set the weights to 20-30% of the maximum value and run the vibrator for a few hours. Once the grease has heated and redistributed in the bearings the amp reading should return to the specified level. Do not run the vibrator when it pulls more amps than what is specified in this manual or on the tag on the vibrator.



Roller Bearing Lubrication Replacement Procedures

The QT2-2000X, QT2-2500X, QT2-3500X and QT2-4500X Quiet Thunder® Vibrator models have roller bearings. Follow these procedures if the bearings have failed and new bearings need to be installed.

Grease: Use Kleuber Isoflex NBU 15 grease.

Replacing Grease: Vibrator roller bearings need to have the grease changed out after every 5,000 hours of use. Follow the recommendations in the table below for the **amount by weight of grease to use when changing out the grease for each roller bearing:**

Grease Needed for Cleaning and Re-greasing Roller Bearings	
Model	Grease Ounces (grams)
QT2-2000X	.43 (12)
QT2-2500X	.57 (16)
QT2-3500X	.57 (16)
QT2-4500X	1.06 (30)

To remove roller bearings to regrease:

1. Disconnect the electrical power and lockout the power supply following OSHA 1910.147.
2. Disconnect the vibrator from the power source by opening the connection box on the vibrator and disconnecting the power cable from the terminal strip.
3. Remove the four fasteners holding the covers in place at each end of the vibrator. Remove the covers.
4. Note the position of the adjustable weights so they can be re-installed in the same position after replacing the bearings.
5. Remove the shaft nut and washer from each end of the shaft.
6. Remove the weights being sure not to lose the key that prevents the weights from rotating on the shaft.
7. Remove the screws holding the bearing housing flanges in place.

8. Press the shaft from the vibrator housing. One bearing housing flange with bearing will be removed with it.

9. Remove the bearing and bearing housing flange from the shaft, then press the shaft through the housing in the opposite direction to remove the other bearing housing flange with bearing.

10. Remove the retaining ring from the bearing housing flange to release the grease retainer cover and bearing from the bearing housing flange.

11. Remove the OLD grease from each bearing using a finger or a tool that will not damage the bearing.

12. Rinse the remaining grease out of the bearing using an appropriate solvent, then allow the bearing to dry. If available, you can use compressed air to blow out the remaining solvent, but do not spin the bearing using the compressed air. This can damage the bearing.

To grease and re-install the roller bearings:

1. Apply new grease in the weight designated in the above table for each bearing. Place the grease directly on the rollers with the fingers and work it in between the moving parts. Turn the rollers to spread the grease to the inner and outer races and to the cage itself.
2. Press the bearings into the bearing housing flanges. Be sure they are fully seated.
3. Install the grease retainer covers and secure them with the retaining rings.
4. Place the first bearing housing flange with bearing into the housing and secure it with the four bolts.
5. From the opposite end of the housing, insert the shaft through the housing and through the bearing. Be sure to properly place any spacers that were used between the shaft and the bearings.
6. Place any required spacers on the opposite end of the shaft, then insert the second bearing housing flange over the shaft and secure it in place to the vibrator housing with the four bolts.
7. Make sure the shaft is free to turn by hand and that it has 0.4 to 1.3 mm of float. If this is not the case, disassemble again and check to make sure the bearings are properly fitted in their housings.

8. Mount the two inner weights (3 inner weights on QT2-3500X and QT2-4500X models) on each end of the shaft. Be sure the key engages fully, so these inner weights turn with the shaft.

9. Install the two outer adjustable weights (three outer adjustable weights on QT2-4500X model) as they were positioned in #4 above. The weight setting must be identical on both ends of the shaft.

10. Secure the weights by installing a washer and nut on each end of the shaft.

11. Install the covers using the four mount fasteners. Be sure the o-rings are properly seated.

12. Connect the power cable to the power strip in the connection box. Be sure to follow the wiring diagram for the appropriate phase and voltage being used.

13. Reconnect the electrical power. Be sure to take amp readings before returning the vibrator to service. If the amp readings are high, but the shaft turns freely, there could be excess grease in the newly greased bearings. Remove the covers and set the weights to 20-30% of the maximum value and run the vibrator for a few hours. Once the grease has heated and redistributed in the bearings the amp reading should return to the specified level. Do NOT run the vibrator when it pulls more amps than what is specified in this manual or on the tag on the vibrator.

Adding Grease: Using the grease fittings located on the top of the vibrator housing above each bearing, follow the recommendations in the table below for the amount by weight of grease to add to each roller bearing.

Adding grease between 5,000 hour maintenance is especially important and will extend bearing life when there are **special conditions, such as:**

- high ambient temperatures
- running the vibrator continuously
- running it at the highest force setting

Grease Needed for Topping off Grease via Grease Fittings	
Model	Grease Ounces (grams)
QT2-2000X	.25 (7)
QT2-2500X	.32 (9)
QT2-3500X	.32 (9)
QT2-4500X	.57 (16)

Locating the grease ports:

Look for **red grease ports** on top of vibrator for these models:

- QT2-2000X-3
- QT2-2500X-3
- QT2-3500X-3



Look for red grease ports on the side of vibrator for this model:

- QT2-4500X-3





XVII. TROUBLESHOOTING

Problem	Probable Cause	Solution
Single phasing 3 phase vibrators only	Circuit breaker is tripped or fuse is blown.	Correct the problem that caused the overload to occur. See pages 8 - 11. Reset breaker or replace fuse .
	Switch or starter contact is not closing properly.	Replace or repair starter.
	Conductor or wiring to vibrator is defective.	Repair or replace conductor.
	Power supply malfunctions, such as the loss of one phase of a distribution transformer caused by lightning, wind, ice storms, etc.	Replace damaged wiring. Replace transformer. You may have to contact local electric utility to repair their circuits.
Excessive noise	Vibrator mount is not rigid.	Make sure mount is rigid and the vibrator is perpendicular to channel iron. See pages 4 - 7. Tighten all bolts. Check for cracked welds or broken housing.
Vibrator will not start	Single phase circuit breaker (purchased separately) is tripped.	Correct the problem that caused the overload. Reset breaker. See pages 8 - 11.
	Circuit is interrupted.	Make sure all leads are "hot".
Vibrator runs hot or overheats <i>(Check voltage and amp draw on start-up and on run.)</i>	Vibrator mount is not rigid	Make sure mount is rigid. See pages 4 - 7. Tighten all bolts. Check for cracked welds or a broken housing.
	Voltage is low. Conductor gauge or extension cord is inadequate or too small.	Use a heavier gauge when using extension cords or conductor. See page 21 for voltage/amp information and how to size an extension cord.
	Stop-Start time intervals too short. The motor is restarted quickly again after stopping.	The time between start-ups needs to be at least two minutes. The amperage draw at start-up is high and creates heat. A two minute time delay allows motor to cool down.
	Ambient temperature is too hot for vibrator.	Protect vibrator from ambient temperature above 104°F (40°C).
Excessive current <i>(Check voltage and amp draw on start-up and on run.)</i>	Vibrator mount is not rigid and/or vibrator is operated on an empty bin.	Make sure mount is rigid and the vibrator is perpendicular to channel iron. Tighten all bolts. Do not operate vibrator on an empty bin. See pages 4 - 7.
	Single phase units - conductor wires may be inadequate, keeping start switch from disengaging starter coils.	See Voltage and Amperage information on page 9.
	Vibrator has too much force.	Adjust weight settings to reduce force. See pages 12 - 14.